



KIT ADMISSION DIRECTE DIRECT INDUCTION KIT

VW POLO GTI 1.6L 16S 125HP
2001

S.A.S
Chrono'Sport
122 rue du faubourg Saint Jean
ZA de l'AVELON - 60000 BEAUVAIS -
FRANCE
00.33.3.44.02.64.64
00.33.3.44.02.87.10

Part n° :P403

FITTING INSTRUCTION

Remove the complete air box .(see diagram A)

Remove the pipes A,B,C and the upper engine top cover.(see diagram A)

Fix the pipe of the kit onto the throttle box (see diagram B,C)

Fix the GREEN filter onto the pipe of the kit with the sleeve provided (see diagram B,C)

Fix the small GREEN filter with the bended connector onto the pipe of the breather.(see diagram C)

Fix the breather pipe with the plastic clamps provided.

Adjust the filter so that it does not touch a mechanical part.

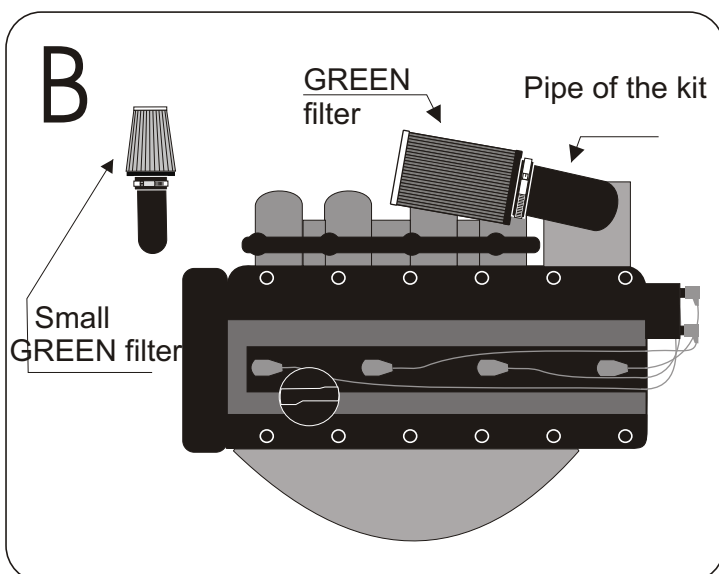
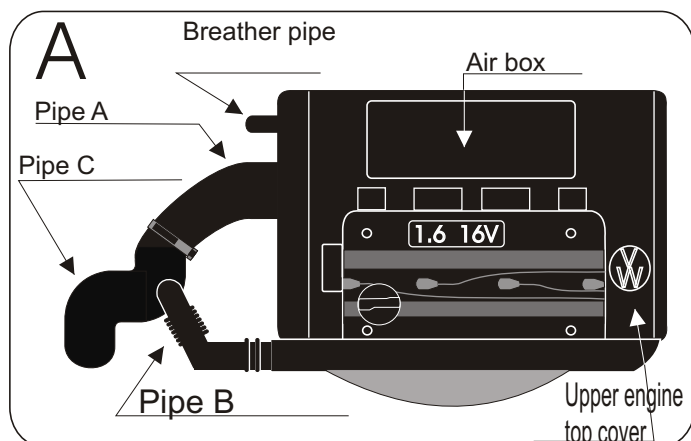
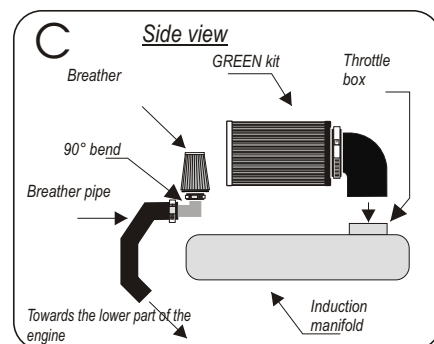

IMPORTANT:

The running of your engine is linked directly with the maintenance of the air filter. Clean your air filter every 7000 kms or 4500 miles with Green cleaning products.

WARRANTY:

The air filter guarantee is for defects in materials and workmanship only. Guarantee is void if the air filter is damaged by an accident, unreasonable use, neglect, misuse, abuse, improper installation or other causes not arising out of defects in materials and workmanship. The induction kit is a technical product so it is necessary to have some basic mechanical skills. If problems do not hesitate to have your induction kit fitted by a professional.